

R16-9DB

Long-range UHF electronic tag reader

Instructions for use



目录

I	The introduction.....	1
1.	Technical parameters.....	1
2.	The dimension structure of the reader	2
3.	The purpose of the reader	2
4.	The main function of the reader	3
II	How the reader works and wiring instructions	4
1.	The wiring instructions for the reader.....	4
2.	Label action	4
3.	How it works.....	5
4.	ID adjacent discrimination.....	5
III	Reader configuration	5
IV	The installation of the reader	6
1.	How the reader is installed.....	6
2.	Reader fixation and height adjustment.....	6
3.	Reader adjudication adjustment	7
4.	Examples of installation - vehicle parking management	7
V	R16-9DB Secondary Development	8

I The introduction

1. This product has a multi-protocol compatible, fast read rate, waterproof design, to meet the requirements of the demanding working environment
2. Full support for ISO-18000-6C (EPC G2) electronic labels;
3. Support for USB,RS232 and Wiegand26/34 and other means of communication;
4. The output power is adjustable up to 30dbm, which supports a variety of operating modes such as timing mode, master mode and trigger mode.
5. Application is suitable for: vehicle access control, non-parking automatic charges, personnel access management, logistics monitoring, production automation management and other fields

1. Technical parameters

Frequency of operation	ISM 902-928MHz or ISM 865-868MHz are available in standard configurations to customize other bands
Antenna gain	Built-in round polarized antenna with gain of 9dBi
agreement	ISO18000-6C (EPC G2)
The development package	Provides SDK development packages, as well as C#,VC, VB, Java, Delphi development routines
Software	Provides test DEMO as well as automatic write card, card reading DEMO,convenient for customers to issue and write cards
Output power	0~30dBm, software adjustable
The communication interface	type N: Wiegand26/34, RS232/RS485, USB Type E: Wiegand26/34, RS232/RS485, TCP, USB
Enter the interface	1 trigger input
How to read the card	Timed automatic card reading and external trigger control card reading, set by the software
The speed at which the card is read	Set by the software, the average single card read is less than 6ms per 64bits
Read distance	0-6m (high power 0 to10m) (read distance is related to labels and field environments).
Operating temperature	-40°C~+65°C
Storage temperature	-45°C~+95°C
Power requirements	DC12V, 3A
size	257mm×257mm×42mm
weight	1.45 Kg(with packing 2.45kg).

2、 The dimension structure of the reader

Unit:mm

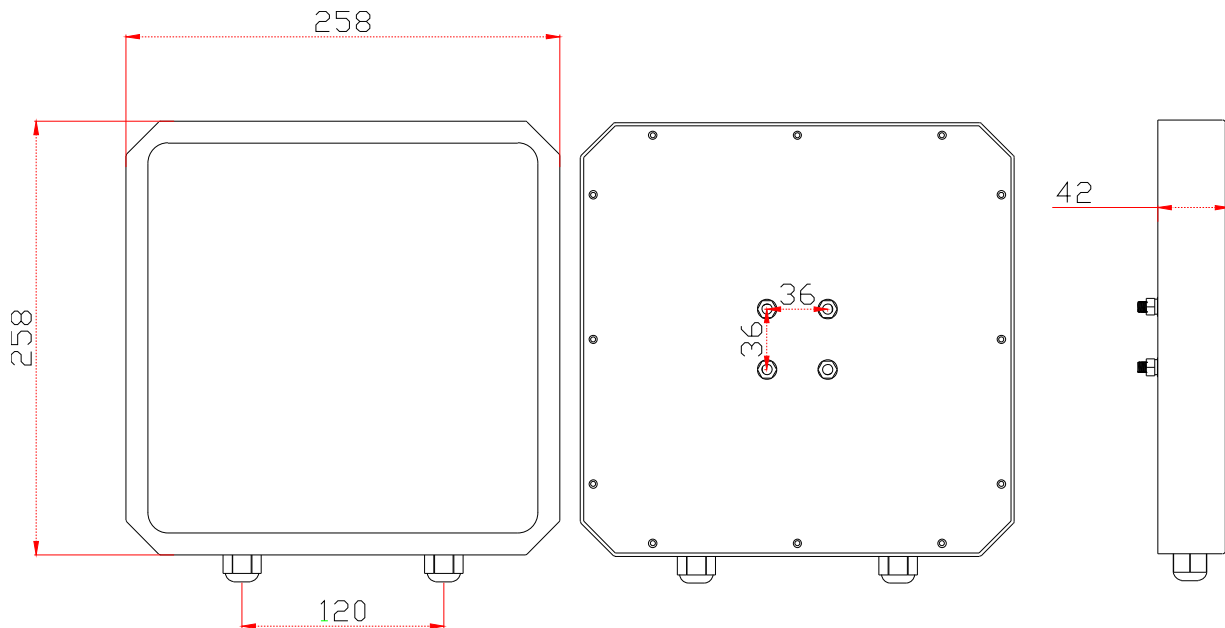

3、 The purpose of the reader

Can be used for item identification and data collection, taking advantage of its good characteristics, especially in the following areas:

1. Transport management: road, rail transport management and container transport management;
2. Motor vehicle management: public security, transportation and other departments of various motor vehicles monitoring and management;
3. Road bridge toll: Because this product has the ability to read label data at high speed over long distances, road bridge toll can be carried out without parking;
4. Customs clearance management: customs clearance, customs clearance of goods and vehicles management;
5. Warehouse logistics management: commodity flow and storage management, as well as mail, parcels, air baggage and other flow management;
6. Parking management: to achieve management and fee automation;
7. Access control management: including vehicle and personnel access management;
8. Process production process: monitoring components throughout the production process;

4、 The main function of the reader

1. Wake-up label: Only the wake-up label can communicate with the reader, prevent interference with other labels outside the system, and ensure the reliable and accurate exchange of information between the reader and the system label information.
2. Read label data: Not only can you read the ID number of the label, but you can also read the data of the specified label store;
3. Write label data: You can write data to the specified label store.
4. It can be connected directly to control devices with standard Wiegand26/34 interfaces, without development and ease of use.
5. Connect to a controller or PC via a standard communication interface for data communication and exchange, and provide SDK development packages for users to further develop applications.
6. Precautions for use
 - 1) R16 series readers are typically connected to computers via the RS232 data interface for data exchange. Since the R16 Series readers can only read and write electronic tags after receiving control commands from the controller, we provide our customers with SDK development packages that users can use to develop applications.
 - 2) The operating temperature of the reader is : -40 degrees C to 65 degrees C. Therefore, when using this reader in cold areas and during the season, care should be taken to pre-start and warm up 15 minutes before the reader is officially used to ensure the proper operation of the reader.
 - 3) It is recommended that you do not have any object blocking within at least 30 meters in front of the reader, and when holding the card, touch your finger to the edges of both sides of the card, as this antenna is horizontally polarized, the card should be placed across the face-to-reader during the test to ensure the card reading effect.
 - 4) The Wigan communication interface must be connected to the GND ground line.
 - 5) The mounting height is more than 1.8M and the pole diameter is 40-60CM.
7. The installation diagram

The diameter of the lever is 40-60mm

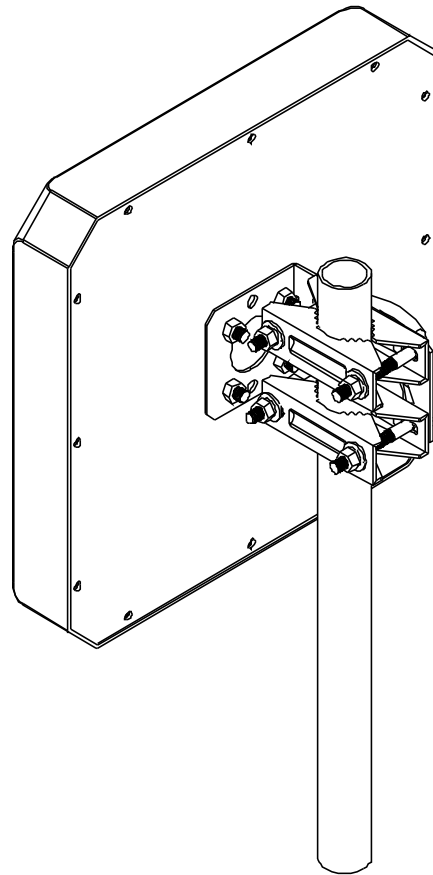
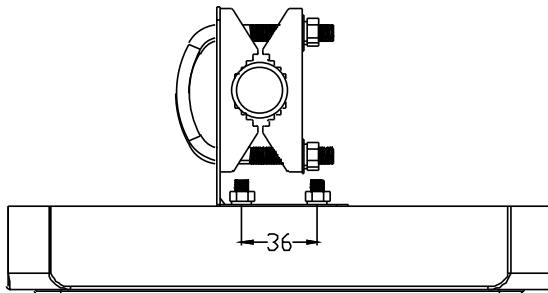

II How the reader works and wiring instructions

1、 The wiring instructions for the reader

red	black	green	white	grey	purple
DC+ (7-12V)	GND	RX	TX	WG-D1	WG-D0

2、 Label action

EPC GEN2 (ISO18000-6C) label

- Single label initialization: Defines the EPC length of the label, typically 96 bits.
- Single label write: Writes the EPC of the label to write one address or multiple addresses at a time (based on one address).
- Single label lock: The EPC that locks the label. Once locked, the label's EPC will not be overwritten.
- Single label destruction: Destroy labels. After destruction, the label will no longer be available.

3、 How it works

1. **Master-from-work mode (COMMAND):**In this mode of operation, the reader operates under the control of a PC or other controller. The reader and the controller can communicate through one of the RS232,RS485, or Ethernet interfaces. This way of working supports all the features provided by the secondary development package.
2. **Timing READ:**The reader automatically reads the card for a certain period (configurable) and the read data is output through the specified communication port. This method is read-only for labels.
3. **Trigger Mode of Operation (TRIGGER READ):**When a low power is entered on the trigger input port, the reader starts reading the card periodically and automatically closes after a period of time.

4、 ID adjacent discrimination

ID adjacency is designed to reduce the redundancy of reader upload data. When this feature is selected, only one set of data is uploaded within a set time when the reader reads the card number of the same label multiple times in a row. Adjacent discrimination can select a valid time, that is, if the adjacent two card reading intervals exceed the valid time, they will not be adjacent to the evaluation. Users should be selected according to specific needs. Commonly used in Wigan communications.

III Reader configuration

The Company provides DEMO software programs for the configuration of the working parameters of the reader. The parameter configurator interface looks like this:

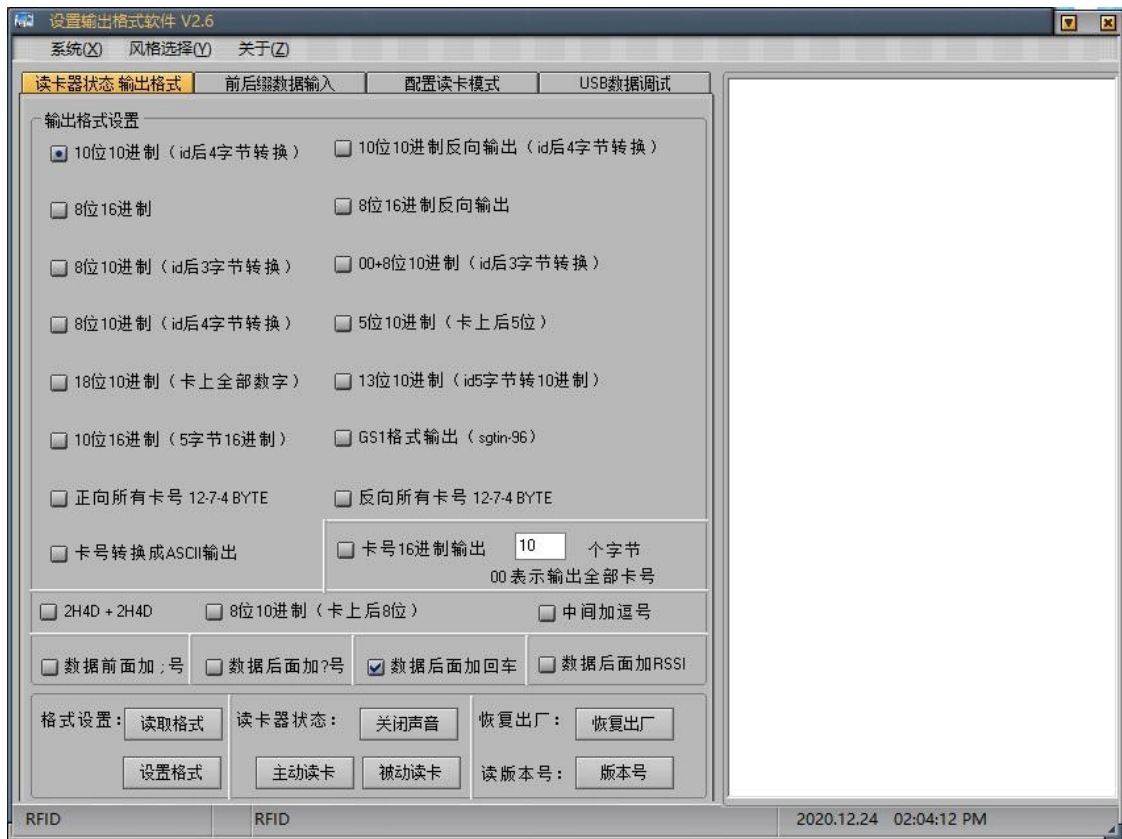

For demo software use, please refer to the <UHF Settings Software Manual>

IV The installation of the reader

1、 How the reader is installed

There are two ways to install a reader stand: "Side 1 type mount" and "L stand mount" see figure below: You can choose the installation method according to the application needs and the actual situation on site. In general, side mount reading and writing distance is closer, but the installation is simple;

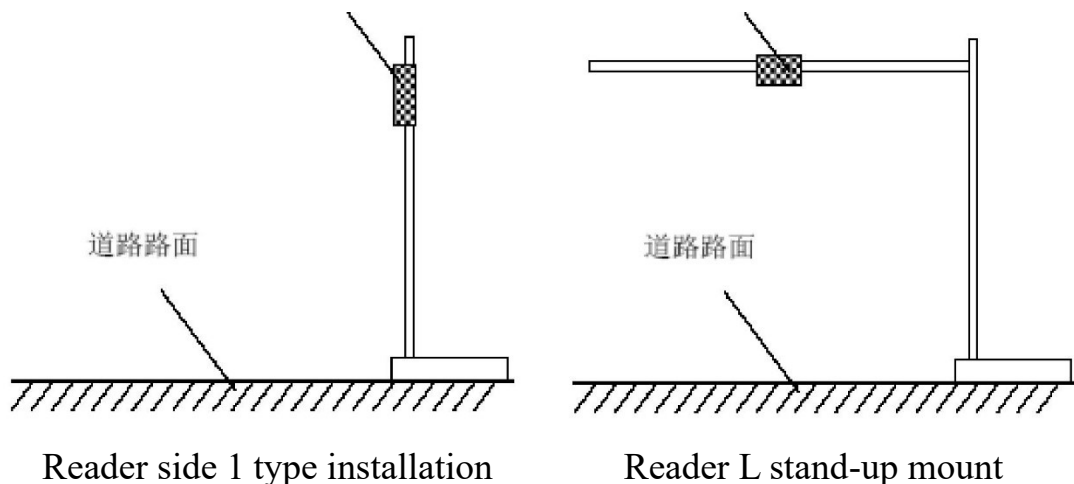

2、 Reader fixation and height adjustment

1 Glyph stand side mounting, the installation of R16-9DB reader diameter 40to60mm,length

2.2m, preferably with a wall thickness greater than 1.2mm stainless steel. Secure the reader to the top of the pole using the fasteners that are included in the R16-9DB reader box. Adjust the height from the center of the R16-9DB reader to the lane level according to the vehicle type (mainly large and small) and generally around 2.0m (1.8to2.2m).) 。

When mounting the L-shaped stand top, it is advisable to install an L-shaped stand pole (or gantry) with a diameter of 60to80mm and a crossbar diameter of 40to60mm, preferably with a wall thickness greater than 1.2-2.0mm stainless steel. Also use the fasteners that are in the box to secure the R16-9DB reader near the middle of the driveway. The height of the crossbar from the ground is adjusted between 3.5m and 4.0m depending on the height of the vehicle.

3、 Reader adjudication adjustment

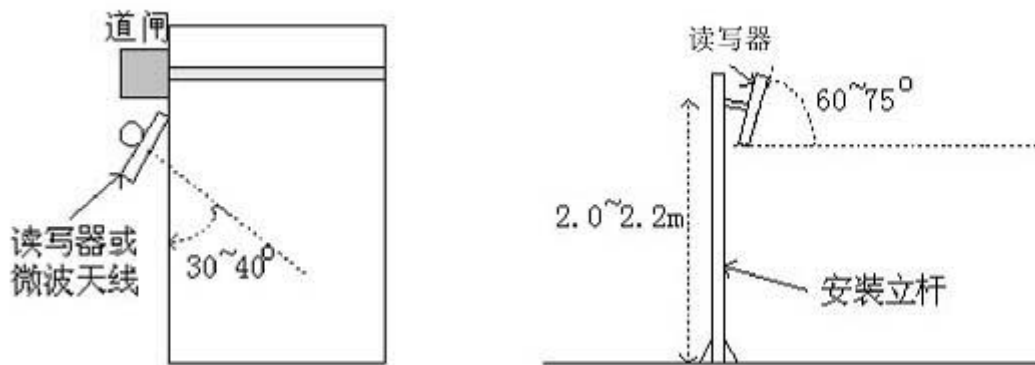

Antenna pitch: refers to the angle between the antenna tilting to the ground and the horizontal line, about 60 to 75degrees

Antenna adage: refers to the offset angle of the antenna in the direction of the lane, about 30 to 40degrees

4、 Examples of installation - vehicle parking management

The principle of selecting the installation location of the R16-9DB reader system is:

1. The R16-9DB reader should not be more than 1 meter away from the gate in a straight line
2. There is no item mask between the location of the R16-9DB reader and the label card
3. R16-9DB readers are as close as possible to the control device (or PC) and require the use of shielded communication cables for specific on-site installation implementation generally determined on the basis of field conditions This is explained below.

1. On-site installation mode 1: the road has no intermediate isolation of the safety island, road control equipment (gate) installed on both sides of the road, vehicles at less than 30 km/h speed through the card reading area.

In this case: It is required that the reader (antenna) should be close to the gate device, while allowing it to read the valid range of the label (the maximum straight-line distance is 0.5 meters to 10 meters) can cover the inlet or exit coils to the entrance and exit, as shown in the following illustration.

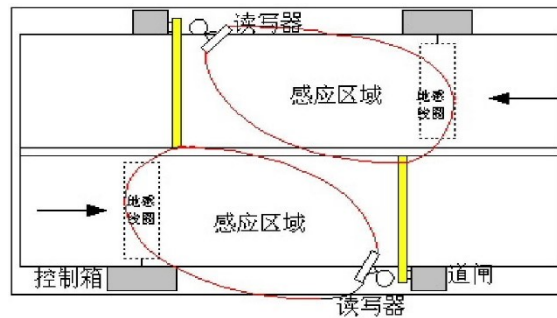

1. On-site installation mode 2: the road has an intermediate isolation of the safety island, control equipment (gate) installed in the middle of the isolated safety island, vehicle speed of less than 10 km / h through the card reading area.

In this case: The R16-9DB reader is required to be close to the gate device while allowing it to read the valid range of the label (up to 0.5 m to 10 m in the farthest straight line) to cover the inlet or exit feel coils at the entrance and exit, as shown in the following illustration.

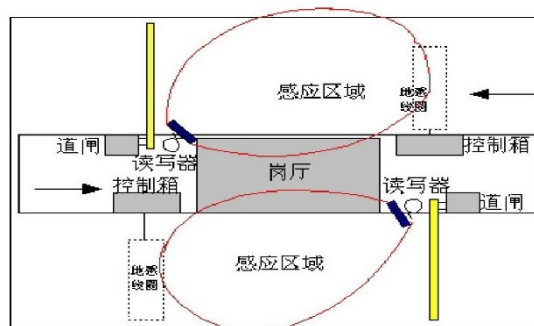

V R16-9DB Secondary Development

The reader application can be developed twice as needed. We provide call routines such as C, VC, VB, Delphi, Java, etc., and WINCE, LINUX drive development, and please refer to the SDK Development Guide for the use of development packages